

CLASS 252-45

170
120
27
13
330

CDE CD-44

ROTOR SYSTEM



OWNER'S MANUAL

CORNELL-DUBILIER CD-44 ROTATOR IS RECOMMENDED FOR ANTENNA ARRAYS NO LARGER THAN 2.5 SQUARE FEET OF WIND SURFACE AREA. FOR LARGER ANTENNAS, UP TO 7.5 SQUARE FEET OF WIND SURFACE AREA, THE CDE HAM II IS RECOMMENDED.

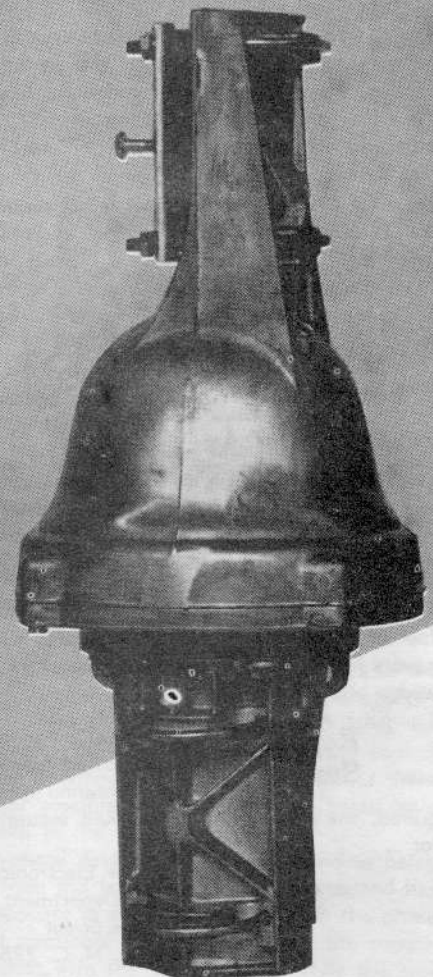

CORNELL-DUBILIER ELECTRONICS

DIVISION OF FEDERAL PACIFIC ELECTRIC COMPANY

Rotor Department

Fuquay-Varina, North Carolina

Foreword

On the following pages, you will find information obtained from the Engineering Staff where the CDR Rotors are built or the Rotor Engineering Group. No attempt has been made to detail every possible installation or suggest every maintenance procedure that may be necessary to cover many years of operation. Please feel free to communicate with us at any time that we may be of assistance. Write to:

CORNELL-DUBILIER ELECTRONICS

Division of Federal Pacific Electric Company

CDR Rotor Department

Fuquay-Varina, North Carolina 27526

Telephone: 919-552-2281

General

The CD-44 rotor system is designed to accommodate light amateur and C.B. antennas with a maximum of 2.5 square feet of wind area. The CD-44 provides a full 360° range of rotation and a meter scale read out for accurate position indication.

The CD-44 is built along the general lines of the original CDE bell type rotator. The weight of the upper mast and the antenna is carried directly in line with the lower supporting mast. The motor, radial and thrust bearings, armature/disc brake, gear train, and indicating sensor are built into the elongated bell shaped cast aluminum housing.

The CD-44 brake is a disc type built into the bottom portion of the motor armature. With the motor at rest, no power applied, the disc brake is engaged by virtue of the weight of the motor armature. When power is applied to the motor, the armature lifts approximately .80 mm (.031") and releases the disc brake.

Terminal 2 on the control unit is not required when used with the CD-44 rotator. This terminal is for the brake solenoid when the control is used with a Ham-II rotator. However, we suggest attaching the #2 control wire to this terminal in order not to leave a loose wire which could short to another terminal.

Control Unit Versatility

The Ham-II/CD-44 Control unit is designed for operation with the Ham-II rotator, part number 50232-00, or the CD-44 rotator, part number 50241-00. If your system demands a larger antenna at a later date, the CD-44 system can be changed to a Ham-II system simply by replacing the rotator unit. The Ham-II rotator unit may be obtained from a dealer or the factory.

The CD-44 rotator will handle antennas with up to 2.5 square feet of wind area. The Ham-II rotator will handle up to 7.5 square feet of wind area and has a positive electrically operated wedge brake.

Repair Service

Cornell-Dubilier maintains a modern well staffed repair department for all CDE antenna rotors. If service is required, the unit should be packed securely and sent prepaid to:

Cornell-Dubilier Electronics
Rotor Service Department
118 East Jones Street
Fuquay-Varina, N. C. 27526

For units that are in warranty, no charge will be made for repair. If the unit is out of warranty, the following flat rate charges apply:

Control box only	\$23.00
Rotator only	25.00
Complete unit	36.00

A check or money order for the amount indicated above should be included. The flat rate charge includes rebuilding the unit and replacing all defective parts. Prices subject to change without notice.

Pre-Installation Check

It is recommended that a preliminary operational check be made on the system prior to actual installation.

Check each item of the system for physical damage due to shipping. The CD-44 system consists of a control unit, a bell rotator unit, a lower mast support, a hardware package and a service manual. If any of these items are missing or damaged, return the complete system to your dealer or the factory for replacement. Sales receipt must accompany such a return.

After the physical check of the equipment, set up the control unit and the Bell rotator for an electrical check. We recommend the following procedure:

1. Measure out the maximum 8-wire control cable required for your particular installation. (See page 8 for maximum cable resistance.) Strip the insulation from all wires, separate the individual wires back about 2-3 inches, and tightly twist the stranded ends. Soldering these ends improves manageability.
2. With the control unit and the rotator on the work table, connect the cable between the two units. Make sure wires 1, 2, 3, 4, 5, 6, 7, and 8 on the control unit are to 1, 2, 3, 4, 5, 6, 7, and 8 on the rotator respectively. CAUTION: No loose strands of wire should touch adjacent terminals or other metal parts of the units.
3. With the rotator sitting in the upright position and connected to the control unit, by the eight (8) wire cable, plug the control unit power cord into a convenient 115 Vac 50/60 Hz wall socket.
4. Turn the power switch on. The meter should be illuminated.
5. Depress the brake release, hold, and simultaneously depress the clockwise direction switch (right). The rotator should turn clockwise (looking from top). This is S-W-N-E-S. Release the direction switch; rotator will coast down and stop. Now release the brake. The rotator is now locked into position.

CAUTION: It is best to release the direction switch prior to end of rotation (extreme clockwise or counterclockwise position) in order not to damage the stop arm and/or the gears.

The rotator is now stopped and the brake is engaged. To turn the rotator counterclockwise, release the brake, hold, and simultaneously depress the counterclockwise switch (left). The rotator will turn counterclockwise. This is S-E-N-W-S.

Prior to actual installation, check the calibration to familiarize yourself with this procedure. It is best done while the system is still set up for the Pre-installation check.

Meter Calibration

Rotators are shipped from the factory stopped in the full counter clockwise (South) position. To calibrate the meter, have the rotator full counter clockwise position, on - off switch "off" and use the zero - center screw to line the needle on the left hand "S" limit. With the on - off switch in the "on" position, push in the calibrate knob. The calibrate knob is a push to calibrate type. (Some models: Push, hold in, calibrate, release. Other models, push, release, calibrate, push again to disengage calibrate circuit.) Locate the needle on the right hand "S" limit. This meter calibration can be performed any time it is desired to check the accuracy. When power is off, the needle will fall to the left hand "S". When power is on, the needle will indicate the antenna position. The zener regulated meter supply will minimize reading variations due to line voltage fluctuations.

Rotator Installation

The CD-44 rotor is shipped from the factory at counterclockwise end of rotation south when viewed from top of rotor.

Install rotor as it comes from factory and point beam south in such a manner that when rotator starts rotating clockwise to other end of rotation the lead wires will not foul.

Wire up the rotator and control box and plug in unit. Meter should read south on left side of dial.

1. The center-of-gravity and center of wind load force of the antenna should be as close to the top of the rotor casting as possible. One to three feet is practical with most installations. When the antenna with a boom length exceeding 8 ft. is to be mounted more than 5 ft. above the top of the rotor, use of a heavy duty tower with the rotor mounted inside is mandatory. The antenna support pipe then should be 2 inch O.D. steel with $\frac{1}{4}$ inch wall, rotating in a ball-thrust bearing at the top of the tower. The rotor should be mounted inside the tower within 4 feet of this bearing to minimize rotating whip in the tubing. All reliable tower manufacturers will be glad to advise the best method for inside mounting with their product. A rugged mount can be made easily with angle iron and "U" bolts that will fit any tower.
2. The CD-44 easily mounts on a pipe or top of tower, but certain precautions must be observed to obtain good service. The rotor can be subjected to tremendous leverage forces. The rotor can be subjected to tremendous leverage forces mounted in this manner, but the thousands of long term successful "top" installations prove its potential feasibility. A careful survey of hundreds of such installations points up several factors. The center-of-gravity and wind loading of the antenna must be centered over the rotor and not more than 12 inches above it if any part of the antenna array is more than 10 feet from the rotor. The reasoning behind this is simple. The ball-thrust bearing races in the base of the CD-44 are just over 6 inches in diameter. 50 lbs. exerted against a 10 ft. lever will place approximately 2,000 lbs. of "pinch" on these bearings. Each additional foot of leverage or pound of force multiplies this value by a high ratio. Extreme care should be used in any very high, top of clear hill installations. Here the wind forces may be applied at odd angles, such as, a severe up-draft that lifts one side of the antenna, multiplying leverage many-fold.
3. Ever effort should be made to eliminate any source of flexure in the mount or antenna. During even moderate breezes, such flexing can set up an oscillating motion that results in thousands of pounds of torque or bending moment. The two degrees of "lost motion" built into every CDE rotor acts as a vibration dampener but can only counteract for moderate swing. After determining proper orientation of rotor and antenna, we suggest that a $\frac{3}{8}$ " hole be bored through the tapped pilot hole in the upper and lower clamp plates—through the support mast—and out through the "V" casting. Then run a $\frac{3}{8}$ " stainless steel bolt and nut of the proper length, tighten securely, through the whole assembly. This is the only known method of insuring no slip at these two points.
4. To summarize: Successful operation of the CD-44 with moderate size antennas is assured if a proper mechanical installation commensurate with the total size of the entire system is made. Please do not attempt another "Easy" 10 ft. by attempting to mount an antenna of any size on top of a 1 $\frac{1}{4}$ inch "T.V." mast on top of the rotor—you are just going to pick up pieces after the first wind gust! Do provide a good mechanically solid support for the rotor at the height desired for the antenna; then keep the center of gravity of the array close to the top of the rotor. If there is any doubt about a "Top" mount, then invest in a good inside tower installation; it is an excellent investment.

The CD-44 is engineered to handle light amateur and C.B. antennas. Long and trouble free performance of the system depends on making the installation to properly handle the stresses involved. CAUTION: THE ROTATOR IS DESIGNED FOR VERTICAL OPERATION WITH THE BELL SHAPED HOUSING IN THE UP POSITION. Water and other contamination will get into the motor unit if mounted horizontal or up-side-down.

Unbalanced Weight

creates a bending moment of force which is concentrated on the mast at the point where it is clamped to the top of the rotor. This moment tends to strain the mast at that point and also to bind the ball bearings by creating excessive downward pressure on one side and upward pressure on the other. Such unbalance places additional stresses on the motor and gear train. Unbalanced weight becomes critical as the distance from the antenna boom to the clamping point at the rotor is increased.

Wind Pressure

against the boom and elements usually produces a bending force on the mast which causes the same stresses as unbalanced weight. To strengthen the installation to withstand unbalanced weight and wind pressure, the top mast should be as short as possible. In order to distribute the bending stress and prevent fracture of the mast, the CD-44 rotor includes two long, heavy, specially designed steel clamping plates. These are grooved to grip the mast securely. It is recommended that the mast be reinforced in the area where it is clamped by driving a hardwood dowel of proper size into the end of the mast.

Mechanical Description

The motor drives a train of spur and pinion speed reduction gears which in turn drive the ring gear. The ring gear drives the bell shaped upper mast support, into which the antenna mast is mounted in rigid central alignment. A boss is cast on the under side and in the center of the cavity of the upper mast support, which engages the serrated edge of the potentiometer arm which is mounted on the top of inner mechanism. Maximum support and low frictional loss between the rotating upper mast support and the inner mechanism is assured by the use of two groups of 25 steel balls each riding in the bearing races between the two assemblies, and held in special nylon retainers. Mechanical stops along with electrical limit switches are built into the rotor mechanism to provide accurate and complete 360 degree rotation.

Circuit Description

Two transformers are mounted in the control unit. The power transformer supplies approximately 30 VAC for releasing the brake and operating the motor when control levers are depressed. Overheating of the transformer from prolonged operation or possible short circuit is prevented by a thermal cut-out switch in the primary winding. The motor is a two-phase device with the first winding being supplied AC direct from the transformer while the second has a 120-140 MFD. capacitor in series in order to shift the phase and provide forward rotational torque. To reverse, the capacitor is switched in series with the first winding, while the second is directly supplied from the transformer. The meter transformer is energized as the on-off control is switched to the "on" position. This illuminates the meter dial and the meter indicates the position of the antenna. 13 VDC is supplied to the 500 OHM potentiometer in the rotator through a zener regulated supply. The meter is a high quality DC instrument requiring 1 MA for full scale deflection. It is connected with plus side through the 10 K multiplier to the plus side of supply and potentiometer, which is protected by a $\frac{1}{8}$ AMP fast blow fuse. The meter

circuit is completed through the 5000 OHM calibrate control and operate/calibrate switch to ground. The operate/calibrate control is located on front panel. With the zener controlled supply the 5K calibrate control will be set at approximately 3000 OHMS which will give 13,000 OHMS in series with meter to allow for 1 MA deflection at full scale.

Two electrical limit switches in the rotator cut the motor power just before the rotation reaches the extremes. A fuse, located on rear panel is also included on one side of the AC power line.

Servicing the Control Unit

Disconnect the AC power source and remove the eight wire control cable. Be sure to tag each wire with the corresponding terminal number.

The control box can be checked without removing the cover by using a volt-ohmmeter to check values across terminals. Resistance across terminals #1-2 should read .4 Ohms. Read same value across terminals #1-5 with clockwise switch lever (right-hand) depressed and across terminals #1-6 with counter-clockwise switch lever (left-hand) depressed. Resistance across input line cord with on-off switch in the "on" position and the brake lever depressed should read 3.8 Ohms.

With power cord connected and on-off switch in the "on" position and brake release lever depressed read approximately 30 VAC across terminals #1-2. With on-off switch in "on" position read $13 \pm 10\%$ VDC across terminals #3-7.

The electrolytic motor capacitor must be of proper value to give adequate motor torque. If a new capacitor is not available for check by substitution, a quite reliable check may be made using the power transformer in the control box and an auxiliary 1 Ohm 10 Watt resistor.

To make this capacitor check, remove cable from terminals and tie terminal #2 to #4. Connect one end of resistor to #1 and the other end to #8. Turn on-off switch to "on" position and depress brake release lever. If capacitor is OK it will draw sufficient current to cause a voltage drop of 1.4 to 1.6 volts to be present across the resistor. Measure with an AC voltmeter.

Checking the Rotator from the Ground

One may possibly avoid bringing the rotator down from the mast by making electrical checks from the position of the control box. This is done by

disconnecting the eight wires from the screw terminals and tagging them carefully #1 through #8 to correspond with the terminal numbers from which they are removed. From the schematic diagram it is apparent that the resistance of the lead wires will be added to the resistance of the motor windings and potentiometer strip in making the resistance checks.

Lead #1 of #18 AWG has approximately 0.64 Ohm resistance per 100 feet and leads #3 through #8 of #22 AWG have approximately 1.6 Ohms resistance per 100 feet. Use a low resistance ohmmeter to check the values shown in the table below to an accuracy of 10 percent after adding the resistance of the leads involved.

To Check	Resistance	Between Terminals
1/2 Motor Winding	1.5 ohms*	1-8
1/2 Motor Winding	1.5 ohms*	1-4
1/2 Motor + Switch	1.5 ohms*	1-5
1/2 Motor + Switch	1.5 ohms*	1-6
Entire Motor	3.0 ohms*	4-8
Right Limit Switch	0 ohms + leads	8-5
Left Limit Switch	0 ohms + leads	4-6
Entire Pot Strip	500 ohms	3-7
Pot Arm to + End	0 to 500 ohms	1-3
Pot Arm to — End	0 to 500 ohms	1-7

* plus leads

Disassembly of Rotator

1. Remove the bottom mast support to permit the rotator to be set on a flat bench.

2. Remove four screws and carefully raise top casting to ex-

pose potentiometer and drive mechanism.

- Carefully remove upper ball retaining ring. Keep it circular, and lay it on clean paper.
- Inspect inside of top housing for small scratches or burned spots on the ribs. These are an indication that a switch blade or connection is rubbing during rotation. See that the pot strip is clean and not burned at either end. See that pot body is secure and that pot arm is clean at the point of contact. Use only fine rouge cloth to polish contact arm. Check limit switch to see if wires are secure and insulation is undamaged. Contacts should be clean. Check for 1/32" clearance between switch blades and motor—particularly alongside of lockwasher under motor fastening. Greater clearance gets switch too close to top bell housing ribs.
- If the drive ring happens to be near end of rotation, operate the top spur gear to rotate the mechanical stop on the drive ring away from the area of the limit switch. See that the mechanical stop lever (which is positioned between the two limit switches) will open each electrical contact before it hits the corresponding mechanical stop. Also see that the stop lever has not been deformed and that the electrical contacts are clear and uncorroded.
- Rotate the top spur gear several revolutions to determine that the motor and its bearings are operating freely. Look for broken teeth in any of the gears.
- Remove the drive ring gear from the base housing. This is accomplished by first pulling up on the side opposite the gear train. Then raise the entire ring slightly upward with the side away from the gear train higher so that it will slide out from under the gears. Examine closely for evidence of broken or worn teeth.
- Examine the inside of the screw terminal strip to see that there is proper clearance between the solid lugs and frame and that there are no faults in the insulation. Pay particular attention to the insulation at the point where the wires are held in metal clips.
- To remove potentiometer, remove hex nuts. Unsolder leads. Mounting studs are staked to the motor frame. Be sure that the pot strip is clean and that pot arm is not corroded. Use only fine rouge cloth as an abrasive. In replacing the pot be sure the connections are on the side which overhangs the motor.
- To replace the motor, first remove the pot per Paragraph 9, then unsolder black motor lead if not done in step 9, the red lead from the inside left limit switch lug, and the blue lead from inside right limit switch lug. Fastenings holding motor on studs may then be removed and the motor pulled up and out. In replacing a motor, be sure to see that the round hole in the motor is next to the limit switch. Use special internal-external lockwasher over the stud that works in the slotted hole in the motor. Be sure that the pinion is snug against the spur gear before tightening this fastening over the slot.
- When it is necessary to closely inspect or replace gears, it is possible to remove motor, limit switch, pot, and terminal strip without unsoldering. Remove motor fastening from the mounting studs. Work motor up and out, exercising care in pulling leads and terminal strip through the window in the gear housing. Remove plate to expose gears. Carefully note positions for proper replacement.

Reassembly of Rotator

It is assumed in the following instructions that the motor and gear train along with potentiometer and limit switch are likewise assembled and wired and operative.

- See that a small amount of low temperature, high quality, light weight grease is conservatively distributed around the ball bearings, ring gear, and spur gears. Only an even film of grease is desirable (approximately one thimbleful of grease should be used to lubricate a completely dry rotator).

Excessive grease will only run out in high temperatures or cause power loss in low temperatures.

2. Rotate upper spur gear until the inwardly protruding mechanical stop on the right gear engages the channel shaped stop lever and pushes it far enough to the right to just open the right hand limit switch contact (it is assumed that the rotator is viewed from the side of the limit switch). This situation represents the extreme counterclockwise end of rotation. The potentiometer arm must then be rotated to its extreme counterclockwise position against the top brass stop.
3. Secure the upper bell housing upside down by the mast support in a vise with the open end of the "V" toward the bench. The boss which drives the potentiometer arm which is located in the bottom part of the bell housing will then be to the left of center.
4. Clean the inner portion of the housing and apply a small amount of grease to the ball race. Then carefully insert one ball bearing assembly with the flanged rim up and against the outer edge of the casting.
5. Grasp the operating mechanism by the flat base, steady the ring gear, invert the mechanism and lower it into the housing. In doing this, note that the serrated portion of the potentiometer arm must engage the driving boss in the housing and that the three driving lugs on the ring gear must engage the mating lugs in the top housing. This situation will result automatically if the previous instructions have been followed.
6. Determine that the top bearing surface is clean and apply a film of grease on the top ball race and the top bearing assembly. Then apply the top bearing assembly to the race with the rim downward.
7. Clean the retaining ring and apply a light film of grease to the ball race only. Lower the retaining ring into place so that the assembly holes will approximately line up with the threaded holes in the upper housing. Insert the 4 assembly screws and use a heavy screwdriver to completely tighten the 4 assembly screws. Torque to 85 inch pounds.
8. It is suggested that all 8 wires be connected from the control box while the rotor is still on the bench and that its complete operation be checked.

Trouble Shooting

Field experience has shown that most operational difficulties with the rotor are traceable to broken, shorted or grounded wires—usually at the terminal strips. Time spent in cutting the leads to exact lengths, tinning, forming, and wrapping around terminals, cutting insulation to exact length, and clamping to prevent strain on any single wire, will pay big dividends later in long and trouble-free performance. Put it up right—and leave it up!

Should trouble occur, first follow the suggestion on page four for "Servicing Control Unit" and "Checking Rotator From Ground". Compare resistance values with Schematic Diagram to localize trouble. The following "symptoms" and "treatments" may also be helpful.

Mechanical Play

To prevent binding under adverse operating conditions, a small amount of play is designed into the rotor. Even a degree or so of rotary play will permit several inches movement at the end of a wide antenna boom, or at the tips of the elements. Frequently the slight motion of the antenna array in gusts of wind is due more to the natural flexing of the elements and masts than it is due to actual play in the rotor mechanism.

Antenna Rotates in Heavy Wind

This is usually a matter of the mast slipping in the support. A false indication of suspected "slipping" can be obtained by comparing meter readings at different times when the beam has not been "rotated

officially." Check the nuts on the U bolts that they are tight. Also check that the center bolt in the mast clamp is tight.

Lack of Power

so that antenna rotation is slow or sluggish. Use method on page four to check motor from ground. Check the capacitor. Check transformer for AC output. If the electrical circuit is OK, then check for mechanical binding. Pay particular attention to bearings and alignment of shaft on an inside tower mount. As a last resort, dismantle the rotor to check gears, bearings, etc.

No Meter Indication

The motor operates independent of the indicating system. If the pilot lights burn at proper brilliancy, the instrument transformer is OK and output is not shorted. Check for about 12 VDC across terminals #3 and #7 with switch operated. If this is present, check for 500 ohms across these leads to rotor (disconnected at control box). If 500 ohms is present from #3 and #7, see if the readings from #3 to ground and #7 to ground total 500 ohms. If this is so, connect an auxiliary meter from terminal #3 to ground and see that voltage runs from zero to about 12 volts as antenna is rotated from left to right extremes.

No Rotation — No Indication

Either the thermal cutout in the power transformer has opened to protect the motor or capacitor from excessive heat of prolonged operation or there is actually trouble in the circuit. After allowing time for the thermal cutout to restore service, proceed with suggestions above for "lack of power".

Grounded Leads

Grounds will burn out either the line fuse or the small fuse in the DC circuit. For full explanations, refer to Schematic. A ground on any of the AC leads #1, #4, #5, #6, or #8 is the same as grounding lead #3 which is common to the AC and DC system. If lead #3 is grounded, it shorts out part of the pot, so that as rotation progresses to the other end, the full DC voltage is applied across a decreasing portion until current becomes so high that it burns out. Note also that any grounds either put an overload on the power transformer which causes the line fuse to blow, or overload the rectifier circuit so that the 1/8 amp. fuse blows.

Meter Fluctuation

An intermittent condition in any component in the rectifier or meter circuits within the control box, as well as in the cable or potentiometer circuit in the rotator itself can cause meter fluctuation or error. Possible causes of such trouble may be localized by placing a test DC meter across terminals #3 and #7 and comparing the action of the test meter with the panel meter.

If the test meter fluctuates along with the panel meter, either a component in the rectifier circuit is intermittently defective, or an intermittent trouble-ground is drawing excessive current. To further localize such a condition, leave the test meter on terminals #3-#7 and remove the corresponding leads to the rotator. This removes the load from the DC circuit so the test meter will show about 12 volts. The panel meter sensitivity will be cut about in half, so it will show about 3/4 scale. Fluctuation of the test panel meters will now point to trouble in the DC rectifier circuit. Fluctuation of panel meter only, will point to intermittent trouble in the meter, multiplier resistors, or the "cal." pot.

Where the meter is steady in preceding tests, and there is fluctuation with rotator leads connected, it indicates trouble in the lead wires or rotator itself. Any dirt, grease or corrosion that breaks or interferes with the ground return from the potentiometer slide will cause the needle to fluctuate from a true reading toward a center scale point. In such cases it is necessary to open the rotator per instructions on page 4.

PARTS AND PRICE LIST

CONTROL UNIT HAM - II/CD-44

50940-00 Control Unit, Complete (115 VAC)		\$89.95	PART NUMBER	DESCRIPTION	Quantity	Price Each
PART NUMBER	DESCRIPTION	Quantity	Price	50861-00	Line Cord, 3 Wire	1 \$ 2.00
	ELECTRICAL			50883-00	Meter, Lamp Holder, and Bezel (N" Center)	1 23.10
10344-03	Fuse, 3 Amp, F-1	1	.30	50895-00	Bulb, Meter	1 .90
10733-01*	Transformer, Power 115 VAC-Std on 50940-00	1	14.50	50899-00	Switch, On-Off, S-1	1 2.00
				50900-00	Switch, Calibration, S-2	1 5.60
				SHEET METAL AND HARDWARE		
30112-05	Switch, Micro S-3, S4, & S-5	3	1.60	10555-00	Strip, Solder Terminal	1 .50
51172-00	Capacitor (120-140 Mfd.) C-2	1	2.50	10563-00	Holder, Fuse, F-1	1 1.90
50153-00	Diode, Zener, D-1	1	4.50	30362-05	Spring, Extension (Meter Bezel)	2 .30
50177-00*	Transformer, Meter 115 VAC-Std. on 50940-00	1	7.00	50185-00	Holder, Fuse, F-2	1 .60
50183-00	Capacitor (30 MFD) C-1	1	1.30	50187-00	Knob, Switch	2 1.00
50202-00*	Transformer, Meter 220 VAC-Std. on 50941-00	1		50194-00	Clamp, Cable	1 .20
50501-00	Diode, 100 Piv. D-2	1	1.00	50300-00	Bumper, Rubber	4 .15
50513-11	Resistor (10K Ohms 1/2W) R-1	1	.35	50399-00	Strip, Terminal (8 Pin)	1 .70
50513-12	Resistor (180 Ohms 1W) R-2	1	.35	50884-00	Lever, Switch (Direction & Brake)	3 .60
50563-00	Fuse, 1/8 Amp., F-2	1	.30	50885-00	Cover, Top (Tan)	1 4.00
				50886-00	Cover, Bottom (Brown)	1 4.50
				50890-00	Face Plate	1 3.10
				50891-00	Chassis	1 6.00

*Note: 115 VAC control unit can be converted to 220 VAC by installation of the 220 VAC power and meter transformers.

10735-01 Transformer, Power, 220 VAC
50202-00 Transformer, Meter, 220 VAC

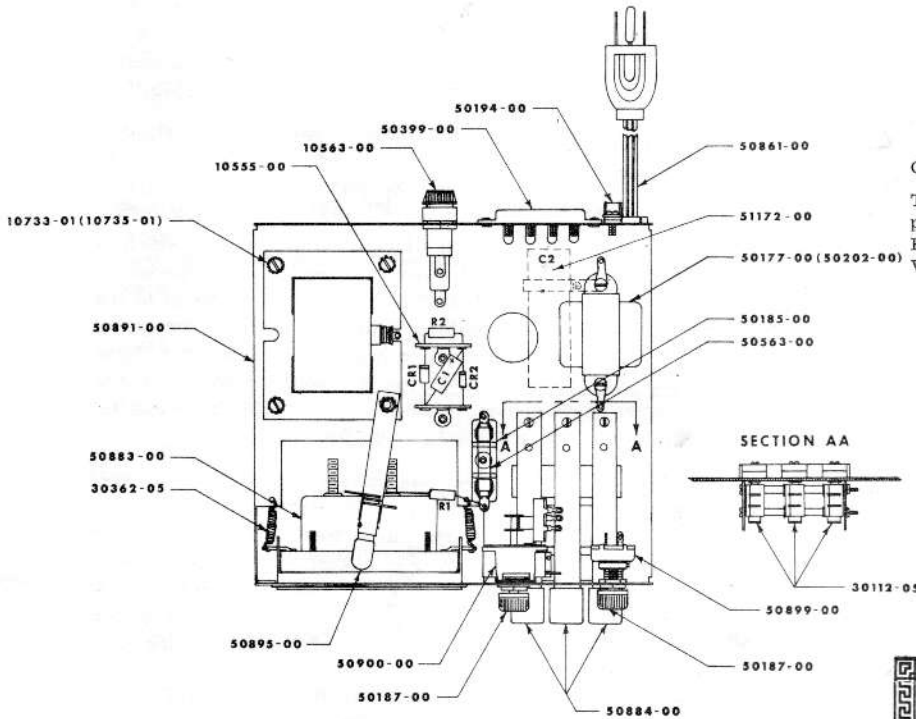

Figure 1

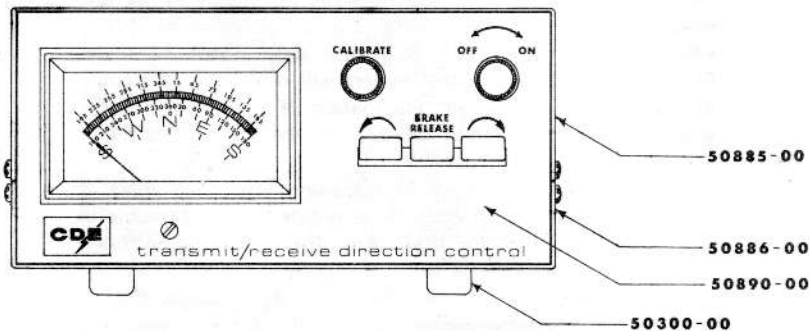

Figure 2

ORDER PARTS USING COMPLETE NUMBER & DESCRIPTION
To order parts, remit check or money order for total parts cost plus \$1.00 for postage and handling to: Cornell-Dubilier Electronics, Department "C", 118 E. Jones Street, Fuquay-Varina, N. C. 27526

Prices subject to change without notice. CDE reserves the right to change prices at its option. Current prices may be obtained by calling or writing the factory. Please send self addressed stamped envelope.

LIMITED WARRANTY

CORNELL-DUBILIER ELECTRIC CORPORATION (CDE) warrants that your new ROTOR has been manufactured free of defects in design, material and workmanship. If this product fails to give satisfactory service due to defects covered by warranty, including any warranty implied by law such as WARRANTIES OF MERCHANTABILITY OR FITNESS, for a period of ONE YEAR FROM THE DATE OF PURCHASE, CDE will, at its option, replace or repair the unit, or any defective part free of charge.

To obtain warranty service, return the ROTOR to your dealer, or pack it securely, and send it with proof of purchase date and a letter explaining the problem, shipping cost prepaid, to: CORNELL-DUBILIER ELECTRIC CORPORATION, WARRANTY REPAIR DEPARTMENT, 118 E. JONES ST., FUQUAY-VARINA, N.C. 27526.

IMPORTANT

Warranty service covers repair or replacement of the ROTOR only. CDE is not responsible for costs of removal or reinstallation, or shipping to the place of repair. The warranty period is not extended due to repair or replacement.

CDE reserves the right to make reasonable charges for service if there is evidence of damage due to alteration, misuse or installation not according to the enclosed instructions.

CDE IS NOT RESPONSIBLE FOR DAMAGE TO OTHER EQUIPMENT OR PROPERTY OR FOR ANY OTHER CONSEQUENTIAL OR INCIDENTAL DAMAGES OF ANY KIND, WHETHER BASED ON CONTRACT, NEGLIGENCE OR STRICT LIABILITY. MAXIMUM LIABILITY SHALL NOT, IN ANY CASE, EXCEED THE PURCHASE PRICE OF THE UNIT.

(Some states do not allow limitations on how long an implied warranty lasts, or the exclusion or limitation of incidental or consequential damages, so the above limitations and exclusion may not apply to you.)

(This warranty gives you specific legal rights. You may also have other rights which may vary from state to state.)

PARTS AND PRICE LIST

ROTATOR UNIT CD-44

PART NO.	DESCRIPTION	QUANTITY	PRICE EACH
50241-00	Rotator Unit Assembly	1	\$47.95
50090-00	End of Rotation Switch Assembly	1	3.30
50107-00	Final Spur Gear	2	2.40
50113-00	Ball Retainer	2	1.10
50122-00	Motor Mounting Plate with Studs	1	2.50
50231-00	Potentiometer Assembly (Complete)	1	9.60
50304-00	Upper Mast Support (Bell Casting)	1	7.00
50425-10	Retaining Ring	1	3.60
50310-00	Motor Pinion	1	.50
50313-10	Ring Gear—Casting Kit	1	2.50
50335-01	Ball Bearings	50	.12
50399-00	Terminal Board Assembly (8 Terminals)	1	.70
50423-10	Stop Lever Assembly Kit	1	1.00
50341-01	Small Gear Spacer (Brass)	1	.30
50346-01	Gear & Pinion (1st, 2nd, & 3rd from Motor)	3	1.20
50369-00	Gear & Pinion (Thick Pinion, 4th. from Motor)	1	1.50
50370-10	Base Kit	1	5.10
50504-00	Motor & Pinion Ass'y	1	14.25
50378-00	Large Gear Spacer (Steel)	1	.40
50379-00	Bushing for Final Gear	1	.40
50349-10	Lower Mast Support Assembly Kit	1	4.50
51057-00	Hex Hd. Screw (Taptite) 12-24x $\frac{3}{4}$	4	.15
02-06006-061	#6—32 x $\frac{3}{8}$ " Self Tap Screw	2	.10
51234-00	Retainer for Stop Lever Assembly	1	.15
51120-00	Washer	3	.10
50463-10	Mounting Kit	1	6.00
	(2) 50115-00 Mast Clamp		
	(4) 50382-00 "U" Type Bolt (Stn. Stl.)		
	(4) 50502-00 Spacer		
	(6) Srew, Hex Hd. $\frac{1}{4}$ -20x1 $\frac{1}{4}$		
	(10) Hex Nut $\frac{1}{4}$ -20 (Stn. Stl.)		
	(14) Lockwasher, Split $\frac{1}{4}$ "		

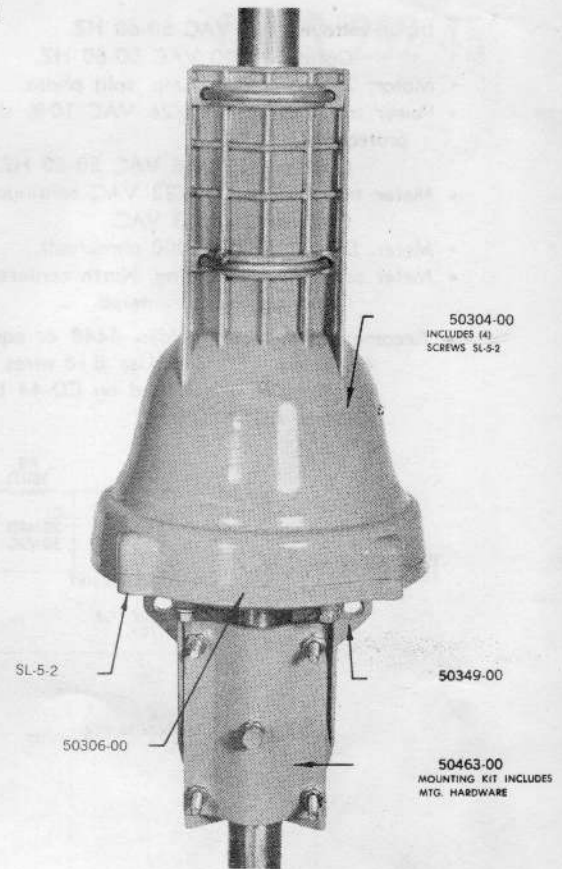

Figure 3

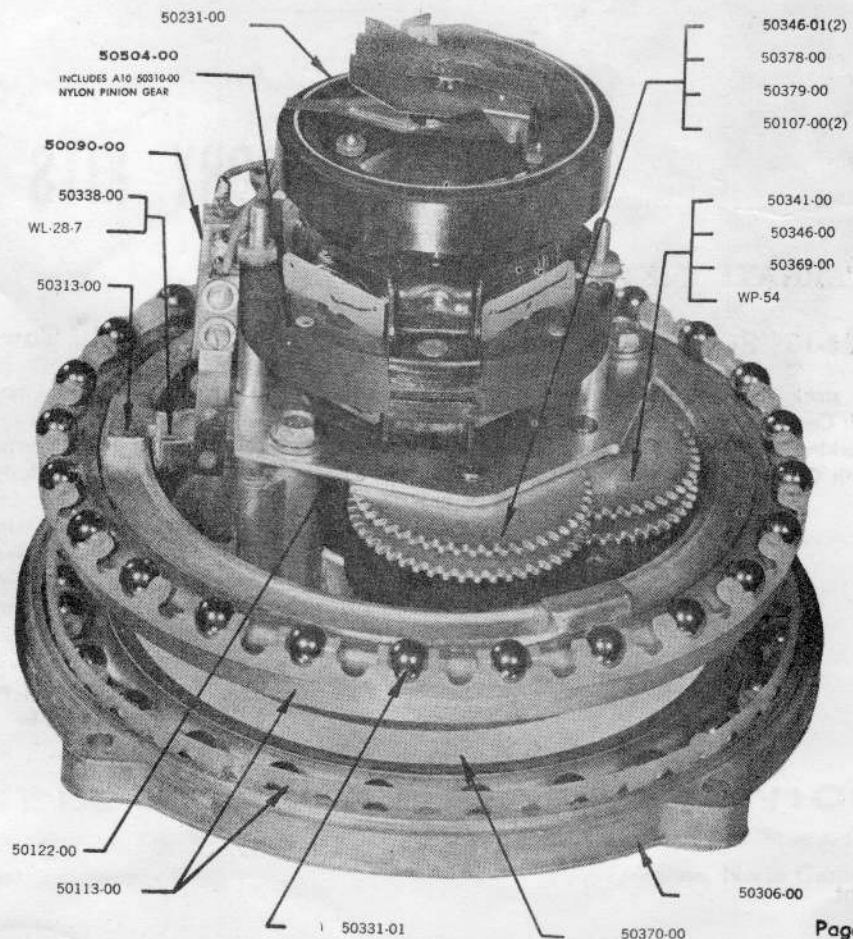

Figure 4

- Input voltage: 115 VAC 50-60 HZ.
Optional: 220 VAC 50-60 HZ.
- Motor: 24 VAC, 2.25 Amp, split phase.
- Power transformer: 115/26 VAC 10% duty, thermal protected.
Optional: 220/26 VAC 50-60 HZ.
- Meter transformer: 115/23 VAC continuous duty.
Optional: 220/23 VAC.
- Meter: D.C. voltmeter 1000 ohms/volt.
- Meter scale: Direct reading, North centered. 5° increments.
Optional: South centered.
- Recommended cable: Belden 8448 or equivalent for up to 45 meters (150 feet). Use #18 wires for terminals 1&2. (Terminal 2 is not used on CD-44 but is required for HAM-II ROTATOR).

- Maximum cable resistance: 2.5 Ohms per terminal.
- Rotation time: 45-60 seconds with 60 HZ input.
- Brake: Disc type. Integral part of the motor armature.
- Rotator size: 20 cm (8") maximum diameter by 44 cm (17 $\frac{3}{8}$ ") high with lower mast support. Without lower mast support, 28 cm (10 $\frac{7}{8}$ ").
- Permissible mast size: From 35 mm (1.37") to 52 mm (2.062").
- Control box size: 20.5 cm (8.125") wide x 21 cm (8.25") deep x 10.5 cm (4.125") high.
- Mounting hardware: Stainless steel.
- Shipping cubature: 37,350 cu cm (2280 cu in).
- Shipping weight: 10.88 kg (24 pounds).

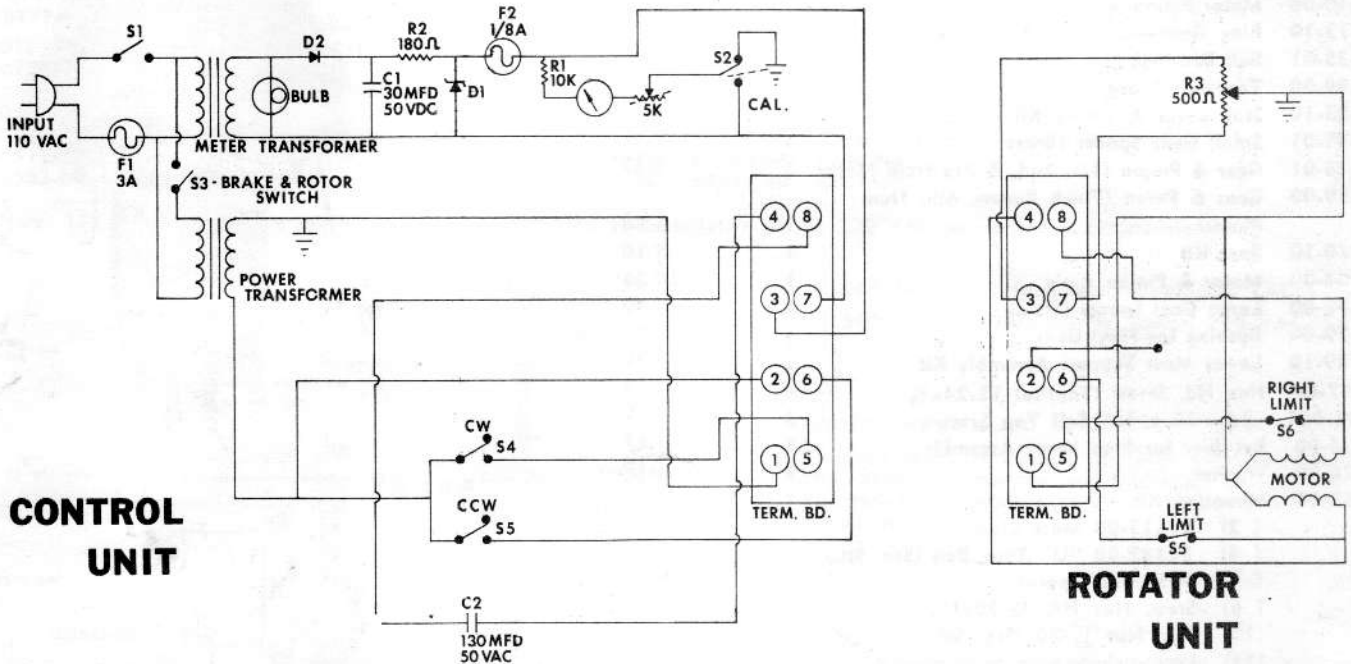

Figure 5

ACCESSORY KITS

ALTERNATE METER SCALE

50924-10 South Center Meter Scale Kit 3.00

The stock Ham II/CD-44 control unit is produced with North Centered meter scale. Since some locations and/or popular working areas may favor rotation stops at North, we provide a South Centered meter scale kit for field modification.

INSIDE TOWER MOUNTS

50559-10 Tower Mounting Plate Kit 4.50

The tower mounting plate kit is a flat plate equipped with four .5 inch standoff bushings drilled to match the hold down screw holes in the bottom of a CDE Bell type rotator. The plate essentially is designed to allow enough clearance under the bottom of the rotator to permit the rotator to turn without touching the 8-wire control cable.

On any inside tower installation, care must be exercised to get the top mast shimmed to the exact rotational center of the rotator upper mast support. The geometry is such that a mast of 52 mm (2.062 inches) will be exactly centered. For each 1.6 mm (.0625 inches) less mast diameter used, .8 mm (.031 inches) of shim must be wrapped around the mast at the clamping points.